

EL PASO COUNTY DEPARTMENT OF HEALTH AND ENVIRONMENT  
INDIVIDUAL SEWAGE DISPOSAL SYSTEM INSPECTION FORM

Permit # 010990  
Date 4/4/97

P. *[Signature]*

APPROVED: YES  NO  #6107012024

ENVIRONMENTALIST *[Signature]*

Address 375 E Kings Deer Pt. Owner Westbrook Co Inc.

Legal Description LOT 2, Amberlea Sub  
Residence , # of bedrooms 4; Commercial ; System Installer Kamal

**SEPTIC TANK:**  
Commercial ; Noncommercial   
Construction Material Concrete, L     , W     , WD      gallons.

**DISPOSAL FIELD:**  
**Rock Systems:**  
Trench: depth     , width     , total length     , sq. feet       
Bed: depth     , length     , width     , sq. feet       
Rock type     , depth     , under PVC     , over PVC       
**Seepage Pits:** # of pits     , total # of rings     , working depth(s)       
size of pit(s) L X W     , lining material     , total sq. feet     

**Rockless Systems:**  
Chamber: Type Infiltrator, number of chambers 70, bed     , trench   
sq. ft./section 155, reduction allowed 40%, sq. ft. required 1351  
total sq. ft. installed 1808, depth of installation 2-3

Engineer Design Y or  N, Designing Engineer       
Approval letter provided? Y or N       
Well 50 feet from tank Y or N      100 feet from leach field Y or N       
Well installed at time of septic system inspection Y or  N Public Water       
\*Approval will be revoked if in the future the well is found to be within 50 feet of the septic tank and/or 100 feet of the disposal field.

NOTES:

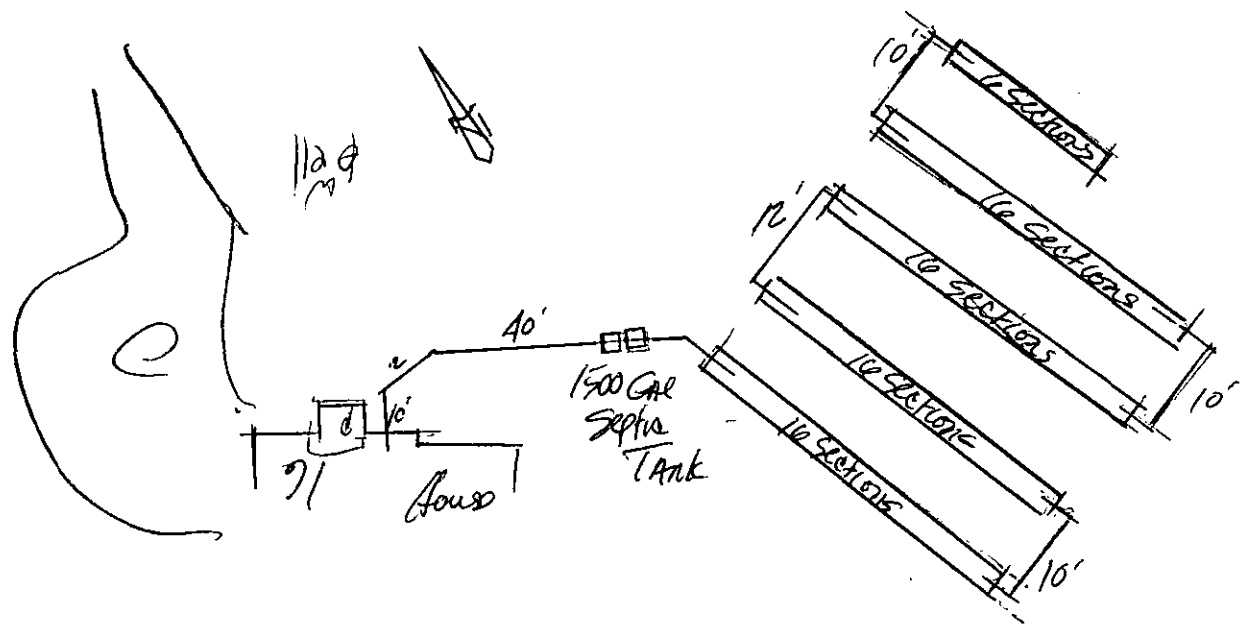

Acres 2.51 **EL PASO COUNTY • DEPARTMENT OF HEALTH AND ENVIRONMENT**  
• 301 South Union Blvd. • Colorado Springs, Colorado • 578-3125

Water Supply WELL

Permit 010990

**TO CONSTRUCT, ALTER, REPAIR OR MODIFY ANY INDIVIDUAL SEWAGE DISPOSAL SYSTEM**  
**WESTBROOK CO INC**

Receipt No. 2/7/97ac

Issued to \_\_\_\_\_ Date 2-6-97

Address of Property 375 KINGS DEER PT RD E, LOT 2 LANGTREE SUBD Phone 481-2988

(Permit valid at this address only)

Sewage-Disposal System work to be performed by RAYS DIGGINS Phone \_\_\_\_\_

This Permit is issued in accordance with 25-10-106 Colorado Revised Statutes 1973, as amended. PERMIT EXPIRES upon completion-installation of sewage-disposal system or at the end of twelve (12) months from date of issue- whichever occurs first-(unless work is in progress). This permit is revokable if all stated requirements are not met.

**-THIS PERMIT DOES NOT DENOTE APPROVAL OF ZONING AND ACREAGE REQUIREMENTS-**

\$150.00

PERMIT FEE (NOT REFUNDABLE)

2-6-98

DATE OF EXPIRATION

[Signature]  
DIRECTOR, DEPARTMENT OF HEALTH AND ENVIRONMENT

[Signature]  
ENVIRONMENTALIST

**NOTE: LEAVE ENTIRE SEWAGE DISPOSAL SYSTEM UNCOVERED FOR FINAL INSPECTION, 48 HOUR ADVANCE NOTICE REQUIRED.**

SEPTIC TANK:	TRENCH SYSTEM:	BED SYSTEM:	SEEPAGE PIT SYSTEM:
total square feet <u>1351</u>	total square feet _____	total square feet _____	total square feet _____
<u>1500</u> gallons	_____ ft. of trench _____ inches wide	_____ ft. of trench _____ inches wide	_____ rings or _____ diam. x _____ w/d

NOTES: **INSTALL IN AREA OF PERC TEST AND AS PER COUNTY REGULATIONS.**  
**A MINIMUM OF 70 CHAMBERS ARE REQUIRED AS PER ENGINEER RECOMMENDATION.**

The Health Office shall assume no responsibility in case of failure or inadequacy of a sewage-disposal system, beyond consulting in good faith with the property owner or representative. Free access to the property shall be authorized at reasonable time for the purpose of making such inspections as are necessary to determine compliance with requirements of this law.



We require the ORIGINAL of your percolation (**PERC**) **TEST**.

The following information must be on your PLOT PLAN.

Property lines

Proposed septic system site

Well(s)

Building(s)

Water line

Subsoil drain(s)

Property dimensions

Designated alternate septic system site

Adjacent property well(s)

Proposed building(s)

Cistern

If any of these are within 100 feet of your proposed septic system include on your plot plan

Spring(s)

Pond(s)

Dry Gulch(s)

Lake(s)

Stream(s)

Natural drainage course(s)

PROPERTY AND PERC HOLES MUST BE CLEARLY MARKED OR POSTED

GIVE COMPLETE DIRECTIONS TO THE PROPERTY FROM A MAIN HIGHWAY

Hwy 105 E. from #25 in Monument;  
to Furrow Rd. ~~L~~ on Furrow Rd.  
to Kings Deer Pt. Rd. E.  
R. on Kings Deer