

REB Approved.

[Signature]

ON-SITE WASTEWATER SYSTEM INSPECTION FORM

PERMIT # ON0033077

APN # 6104003021

DATE: 2/28/2014

P

APPROVED YES NO

Environmental Health Specialist: Celeste Baker, REHS

Address: 1935 Bashley Rd, Monument, CO 80130

Owner: Paul Thompson

Residence: #Bedrooms: 5 Commercial: Enter System Installer: Hazelton Excavating

SEPTIC TANK: Construction Material Concrete

Capacity Gallon 2250

DISPOSAL FIELD:

Trench: Depth (Range): Width: Total Length: Sq. Ft.:

Bed: Depth (Range): Width: Total Length: Sq. Ft.:

Depth of Rock: Under PVC: Type of cover on Rock:

DRYWELLS: # of Pits: Rings(Pit 1): Rings(Pit2): Working Depth #1: #2:

Size (L x W) #1 #2 Total Sq. Ft.

ROCKLESS SYSTEMS:

Standard Chamber: YES Type: Arc 36 #Chambers: 80 Sq. Ft./Chamber: 12.5 Bed: Trench:

Reduction Allowed%: 40% Sq. Ft. Required: 1650 Depth (Range): 2-3'

Sq. Ft. Installed: 1000 Equivalent Sq. Ft. Installed with Reduction: 1666

Engineer Design: Y N Engineering Firm:

Approval Letter Provided: Y N

Well installed at time of septic inspection: Y N Public Water: Y N

**Approval will be revoked if in the future the well is found to be within 50 feet of the septic tank and/or 100 feet of the disposal field.*

Notes:

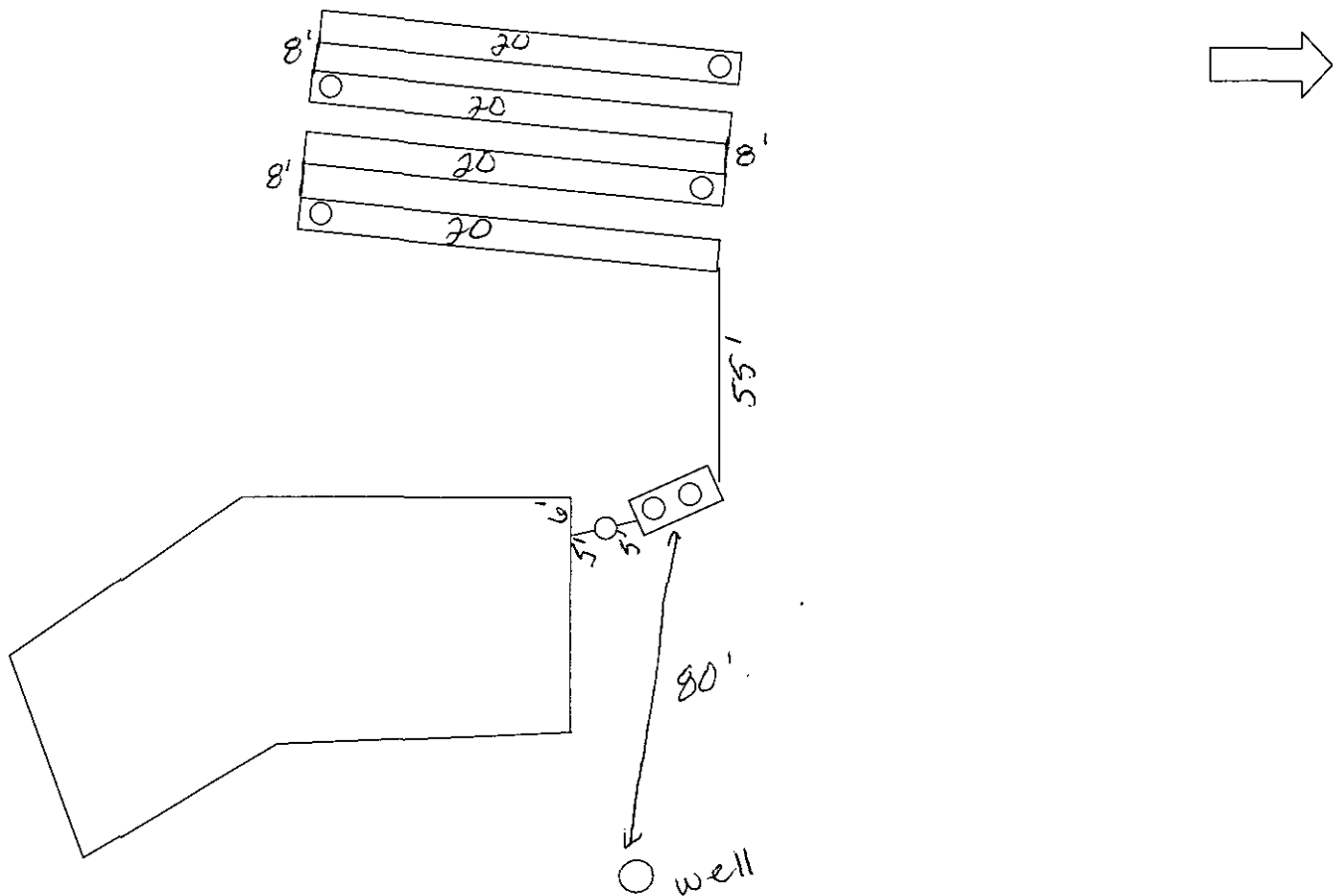

Notify Environmental Health of any change of ownership, type of business activity, business name, or billing address by calling (719) 578-3199. Failure to notify Environmental Health may result in late penalties, Permit/License denial or revocation, and business closure. PERMITS/LICENSES TO OPERATE AND ANNUAL FEE PAYMENTS ARE NOT TRANSFERABLE. Permits become void on change of ownership. New owners must apply and pay for a new Permit(s)/License(s) prior to beginning operation.

Attn: PAUL THOMPSON
1935 BASHLEY RD
MONUMENT, CO 80130

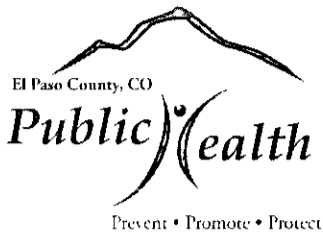

**EL PASO COUNTY PUBLIC HEALTH
ENVIRONMENTAL HEALTH DIVISION**
1675 W. GARDEN OF THE GODS ROAD, SUITE 2044
COLORADO SPRINGS, CO 80907
PHONE: (719) 578-3199 FAX: (719) 578-3188
www.elpasocountyhealth.org

NEW SYSTEM PERMIT - OWTS

Valid From 9/6/2013 To 9/6/2014

PERMITEE :

PAUL THOMPSON
1935 BASHLEY RD
MONUMENT, CO 80130

Onsite ID: ON0033077

Tax Schedule # : 6104003021

Permit Issue Date: 09/06/2013

Dwelling Type: RESIDENTIAL

of Bedrooms (if Res): 5

Proposed Use (if Comm):

Designed Gallons/Day:

Water Source: PRIVATE WELL

OWNER NAME :

PAUL THOMPSON

System Installation Requirements :

1. A shallow trench system is preferred with a maximum cover over chambers of 48 inches.
2. If a bed system is installed, it shall not exceed the maximum width of 12 feet.

Septic Tank Capacity Required: 1750 (Gallons) Soil Treatment Area Required: 1650 (SQ. Feet)

The Health Officer shall assume no responsibility in case of failure or inadequacy of an Onsite Wastewater Treatment System, beyond consulting in good faith with the property owner or representative. Access to the property shall be authorized at reasonable time for the purpose of making such inspections as are necessary to determine compliance with the requirements of this law (permit)

**Installer inspection request line: Call (719) 575-8699 before 8:30 a.m. of the day that the inspection is requested
Weekends & Holidays excluded.**

This permit is issued in accordance with 25-10-106 Colorado Revised Statutes. The PERMIT EXPIRES upon completion/installation of the Onsite Wastewater Treatment System, or at the end of twelve (12) months from date of issue, whichever occurs first. If both a Building Permit and an Onsite Wastewater Treatment System Permit are issued for the same property and construction has not commenced prior to the expiration date of the Building Permit, the Onsite Wastewater Permit shall expire at the same time as the Building Permit. This permit is revocable if all stated requirements are not met. Onsite Wastewater Treatment System to be installed by an El Paso County Licensed System Contractor, or the property owner.

Authorized By: Environmental Health Specialist



See 0000668
AR 0004678

Environmental Health Division

1675 W. Garden of the Gods Rd., Suite 2044
Colorado Springs, CO 80907
(719) 578-3199 phone
(719) 578-3188 fax
www.elpasocountyhealth.org

Prevent • Promote • Protect

APPLICATION FOR AN ON-SITE WASTEWATER TREATMENT SYSTEM PERMIT

NEW PERMIT MAJOR REPAIR PERMIT MINOR REPAIR PERMIT

Owner PAUL THOMPSON Daytime Phone 303-489-0550
System Installer HAZELTON EXCAVATING Daytime Phone 719-237-3677
Property Address 1935 BASHLEY RD, MONUMENT, CO 80132
Owners Mailing Address 5053 HEATHERGLEN DR., HIGHLANDS RANCH, CO 80130
Email Address Klersch@comcast.net Fax # 303-484-6384
Tax Schedule # 6104003021 Lot Size 2.5 ACRES
Site Located Inside City Limits Yes No Primary Contact Owner Contractor
Proposed Use: Single Family Multi-Family Commercial
Water Supply: Well Cistern Municipal Number of Bedrooms 5
 Pick up: _____ Fax: _____ Email: Klersch@comcast.net

CURRENT FEES AS APPROVED BY THE EI PASO COUNTY BOARD OF HEALTH

New Permit: \$440.00 (EPCPH Charge) + \$147.00 (EPC Planning Dept. Surcharge) + \$23.00 (CDPHE Surcharge) = \$610.00

Major Repair Permit: \$494.00 (EPCPH Charge) + \$23.00 (CDPHE Surcharge) = \$517.00

Minor Repair Permit: \$188.00 (EPCPH Charge) + \$23.00 (CDPHE Surcharge) = \$211.00

- All Payments are due at the time of application submittal; by cash, check or major credit card (Visa / MC)
- This permit will expire one year from the date of issuance.

I certify that the information provided on this application is in compliance with Section 8.3, Chapter 8 of the Onsite Wastewater System (OWS) Regulations of the El Paso County Board of Health. I also authorize the assigned representative of El Paso County Public Health to enter onto this property in order to obtain information necessary for the issuance of a permit.

Applicants Signature: [Signature] Date: 9/3/13

Site Insp. Date: 9/5/13 Perc. Rate: 20.2 Permit # ON 0033077

E.H.S. Review Notes: _____

Date to: E.P.C. Development Services 9/4/13 Flood Plain and Enumerations 9/5/13

Permit Requirements: _____

1750 gal Min. Septic Tank Capacity 1650 sq ft Min. Absorption Area

E.H. Specialist Celeste Parker Date 9/16/13 Approved Denied

Celeste